

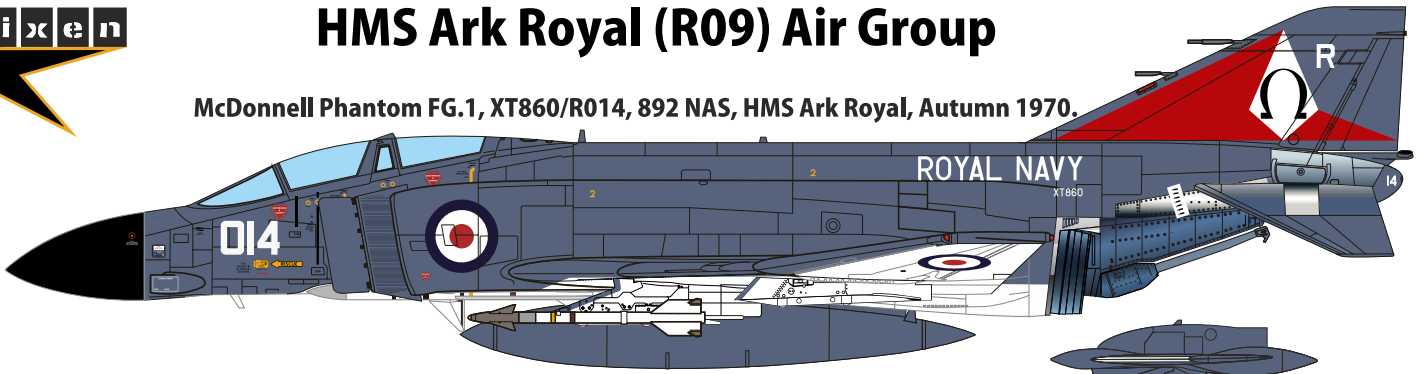

HMS Ark Royal (R09) Air Group

McDonnell Phantom FG.1, XT860/R014, 892 NAS, HMS Ark Royal, Autumn 1970.

#49



SCALE 1:48

Blackburn Buccaneer S.2C, XV343/R033, 809 NAS, HMS Ark Royal, Autumn 1970.

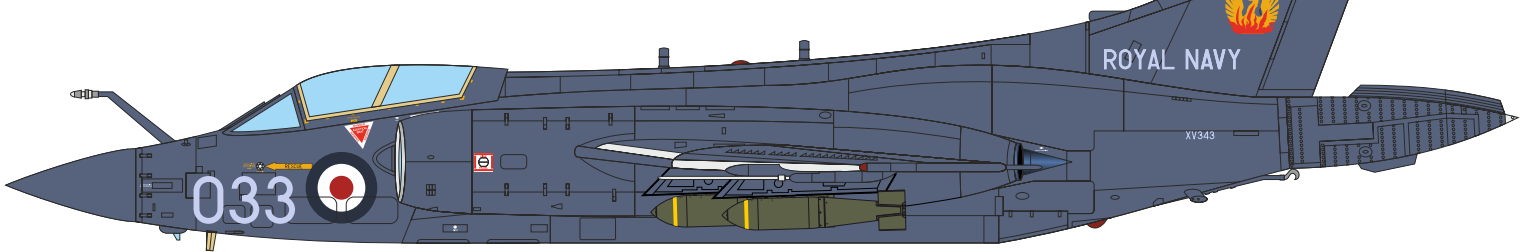

Westland Sea King HAS.1, XV654/R050, 824 NAS, HMS Ark Royal, Autumn 1970.

All Roundels are the same size -36'

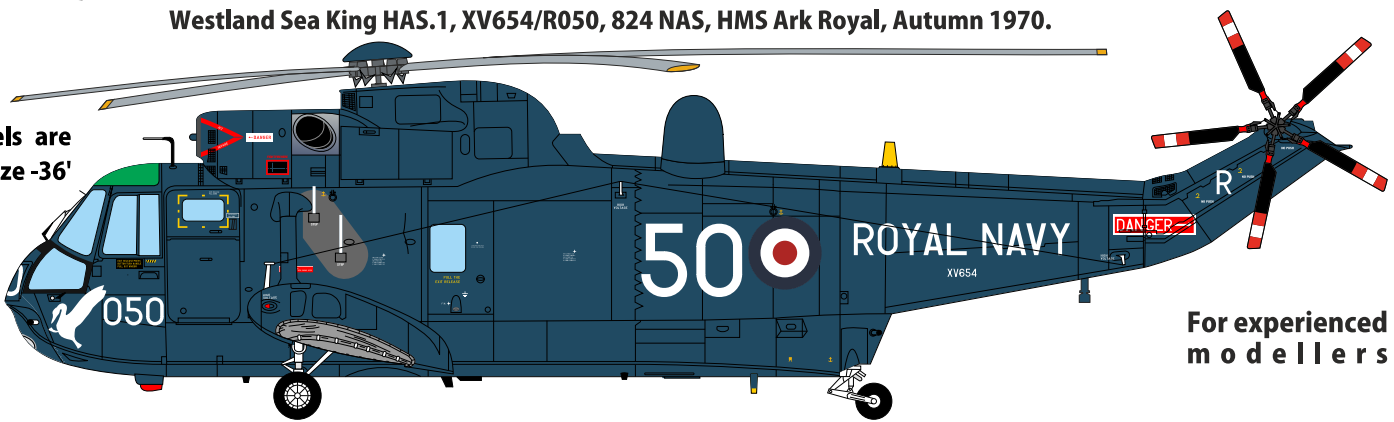

For experienced modellers

Westland Wessex HAS.1, XS880/R057, Ark Royal Ship's Flight, HMS Ark Royal, Autumn 1970.

BS 381 Color chart

Fluorescent Day-Glo Blaze

White

640

633

210

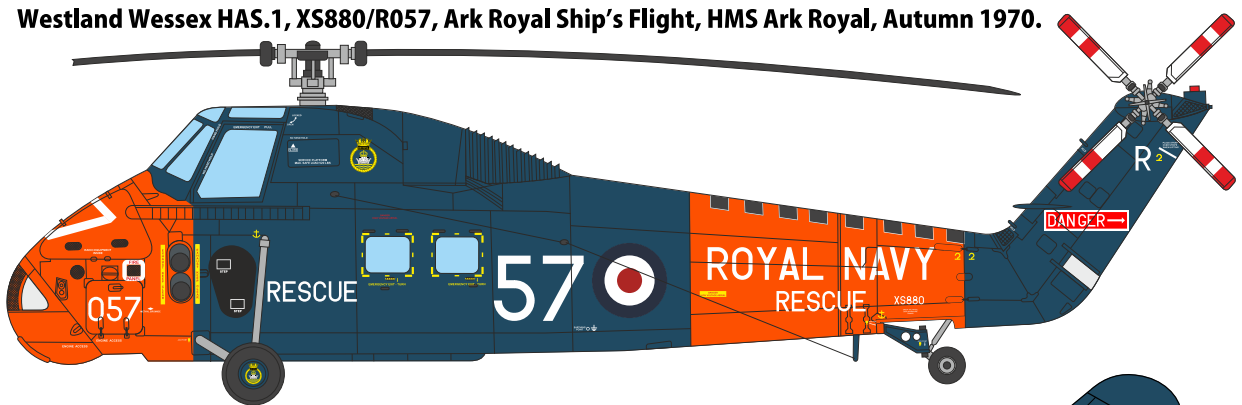

Fairey Gannet COD.4, XG790/R040, 849 NAS 'B' Flight, HMS Ark Royal, Autumn 1970.

All Roundels are the same size -36'

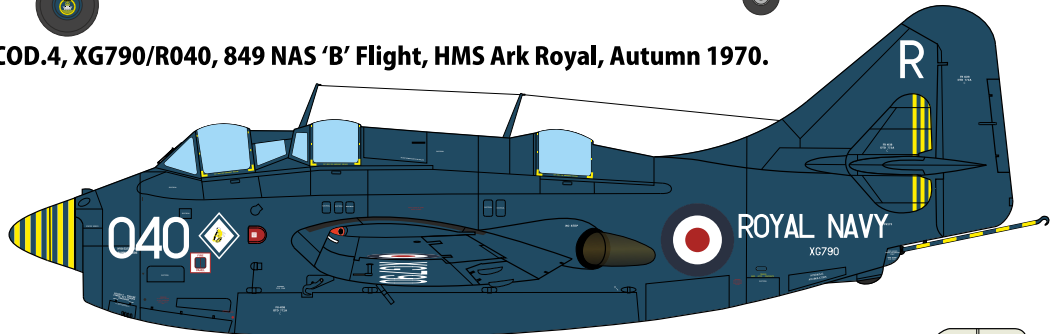

Fairey Gannet AEW.3, XL494/R041, 849 NAS 'B' Flight, HMS Ark Royal, Autumn 1970.

Use photograph and/or your kit's manual for reference. Also note that real aircraft finish is a subject of weathering and this complicated the matter even further.

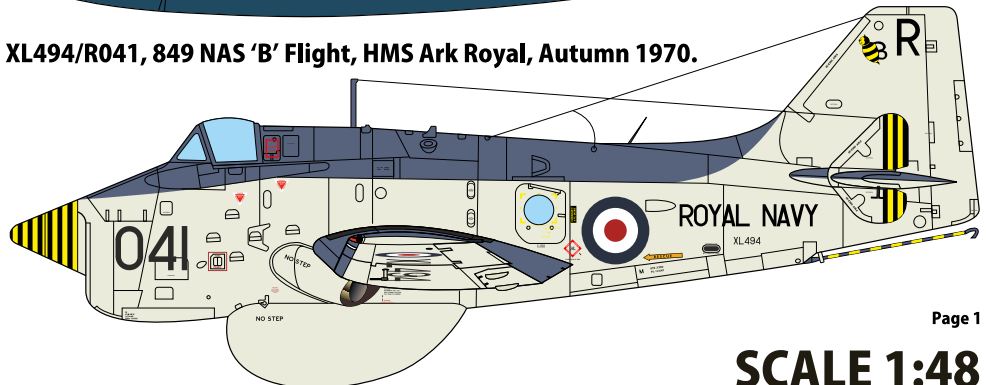

So, take a look at the photos - and paint your kit as you like.

#49

For experienced modellers

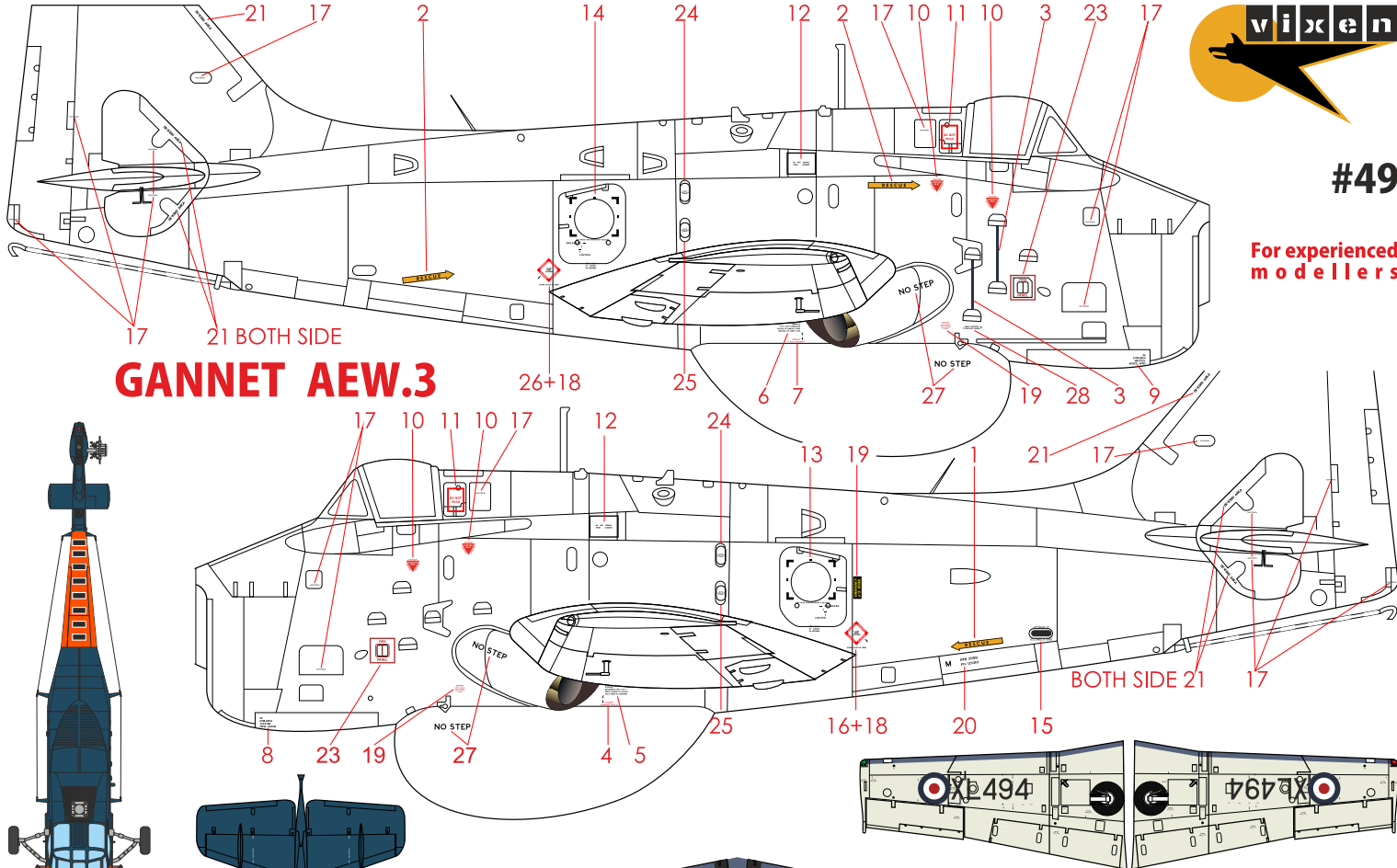

GANNET AEW.3

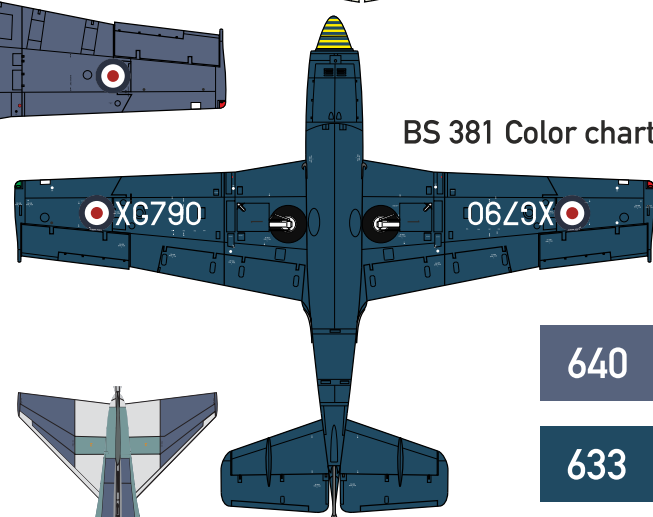
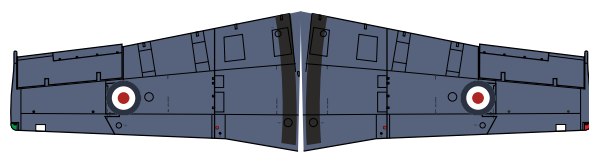
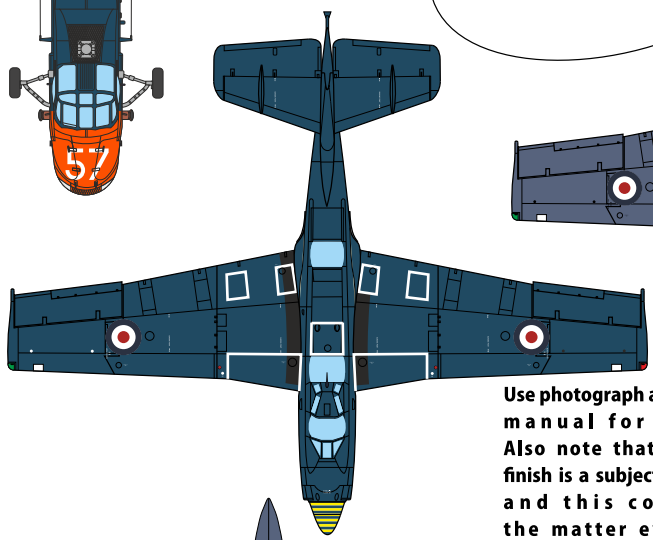
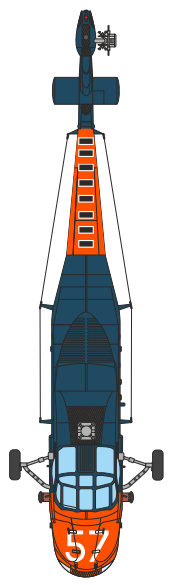

Use photograph and/or your kit's manual for reference. Also note that real aircraft finish is a subject of weathering and this complicated the matter even further. So, take a look at the photos - and paint your kit as you like.

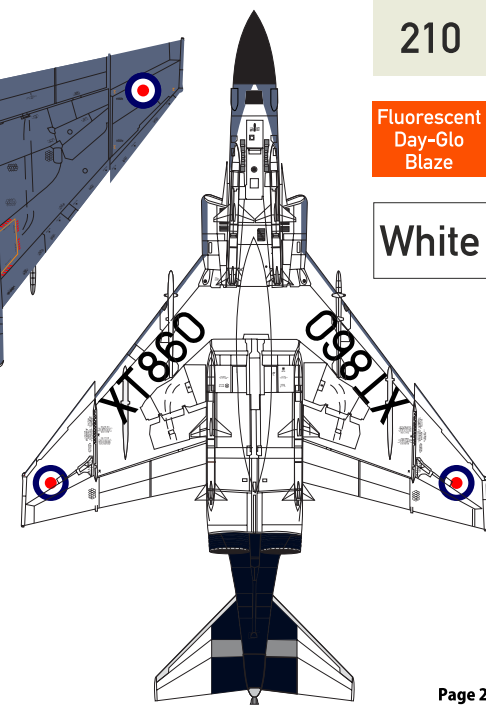
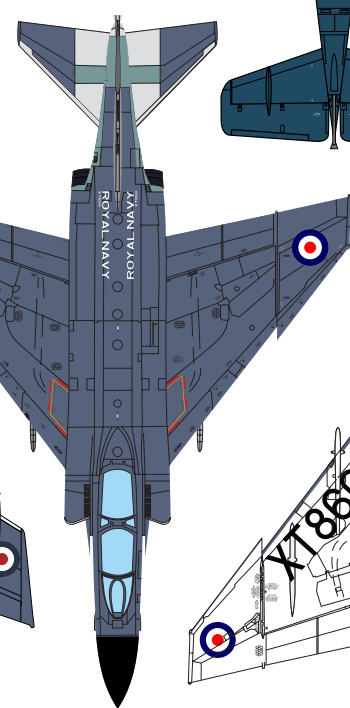
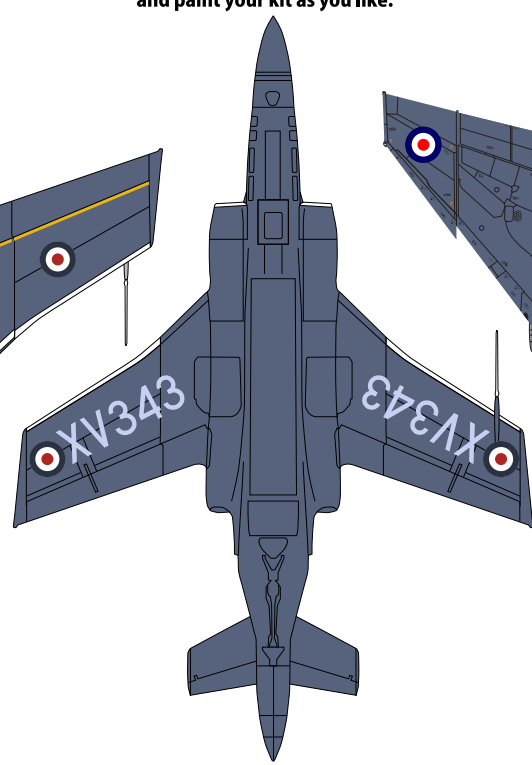
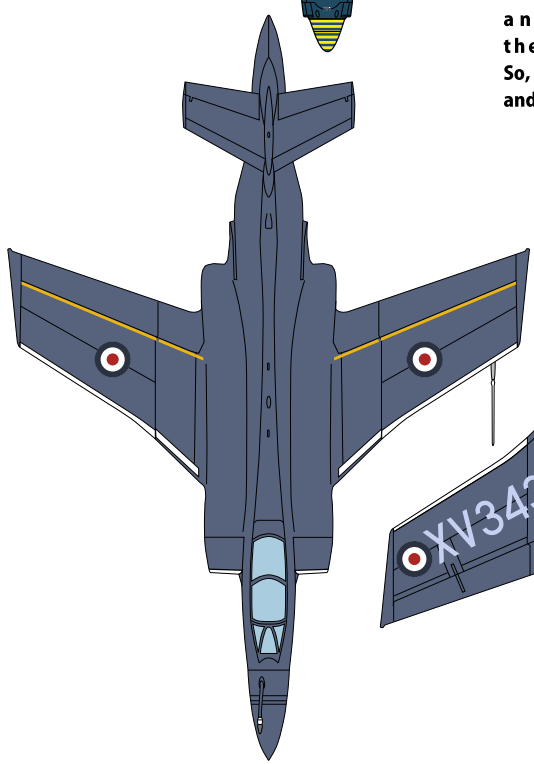

- 640
- 633
- 210
- Fluorescent Day-Glo Blaze
- White

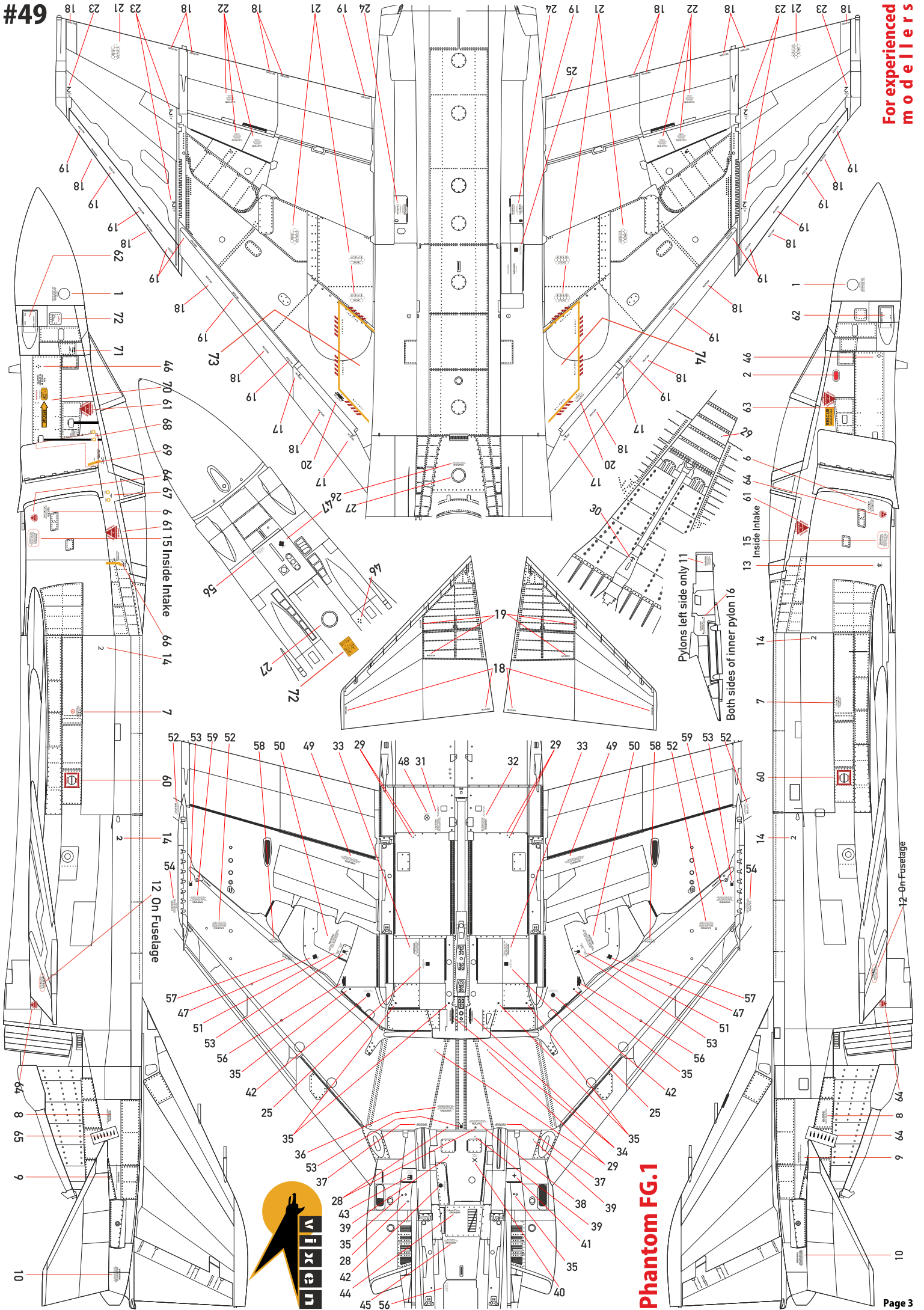

Phantom FG.1





For experienced modellers

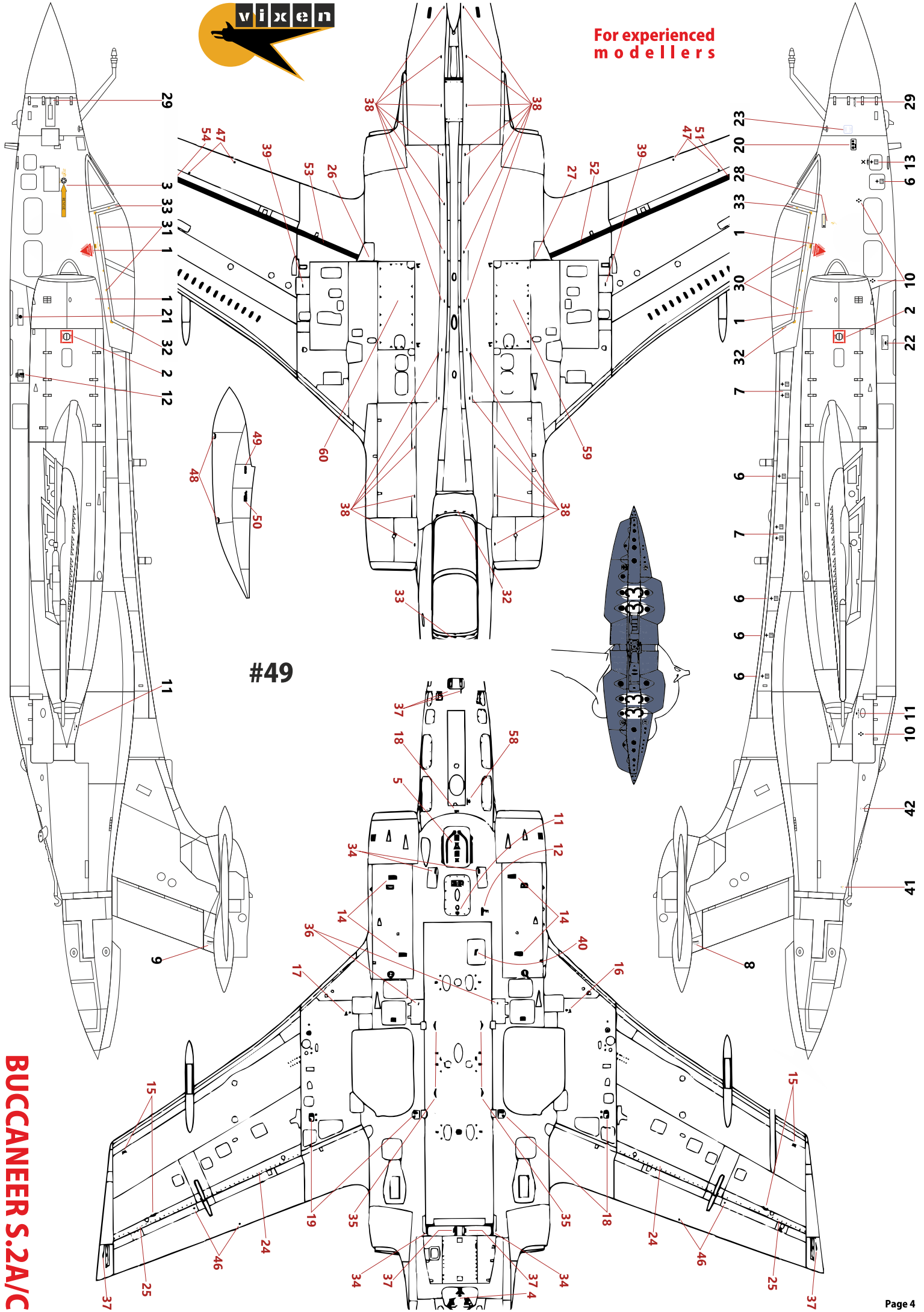

#49

BUCCANEER S.2A/C

#49

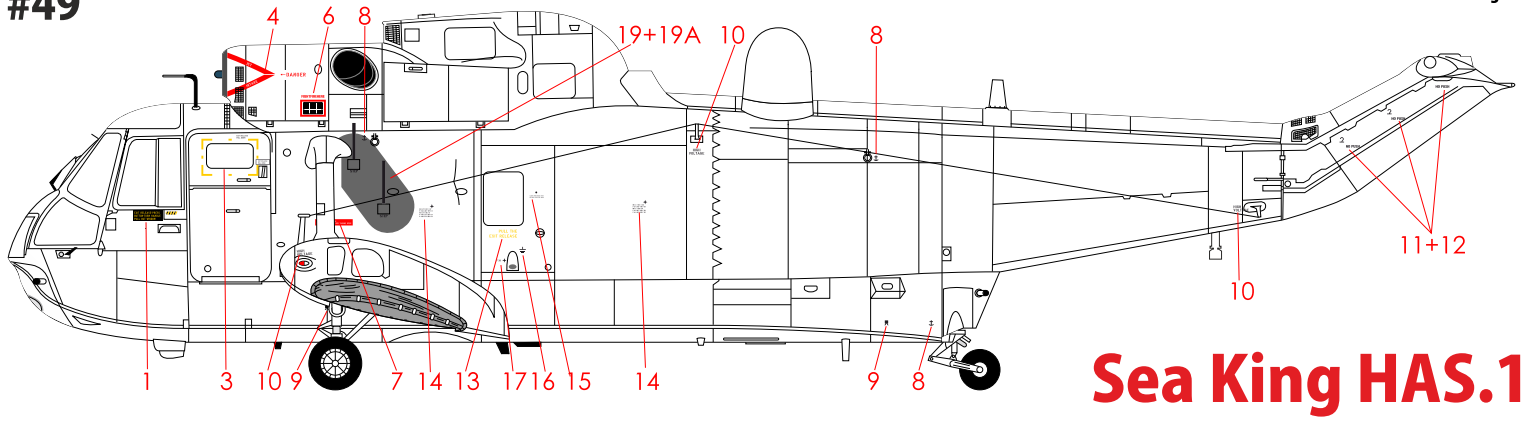

Sea King HAS.1

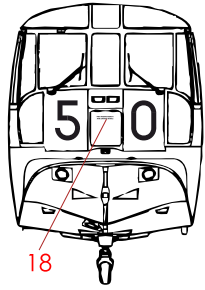
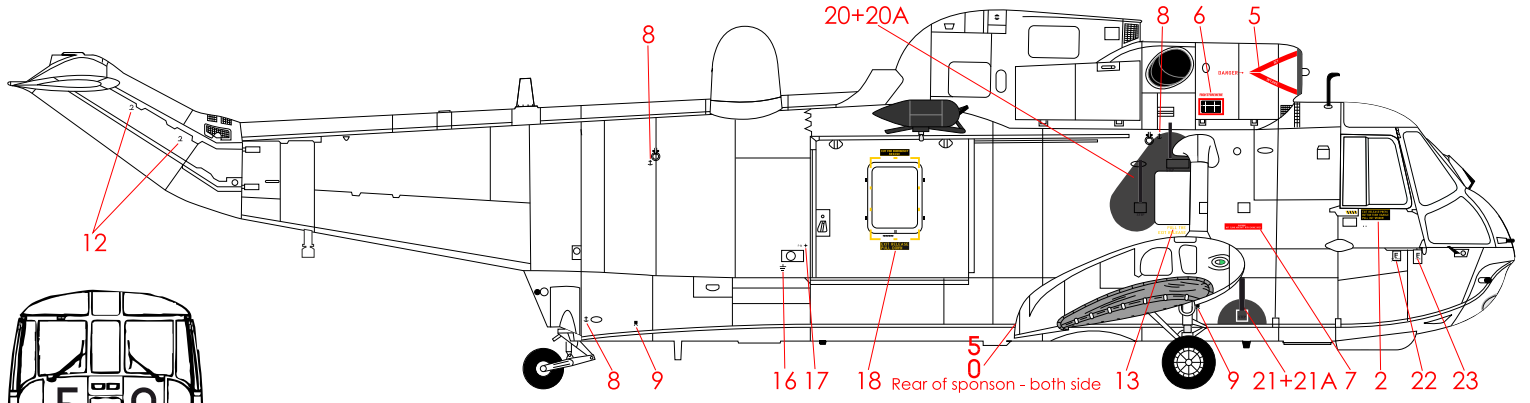

For experienced modellers

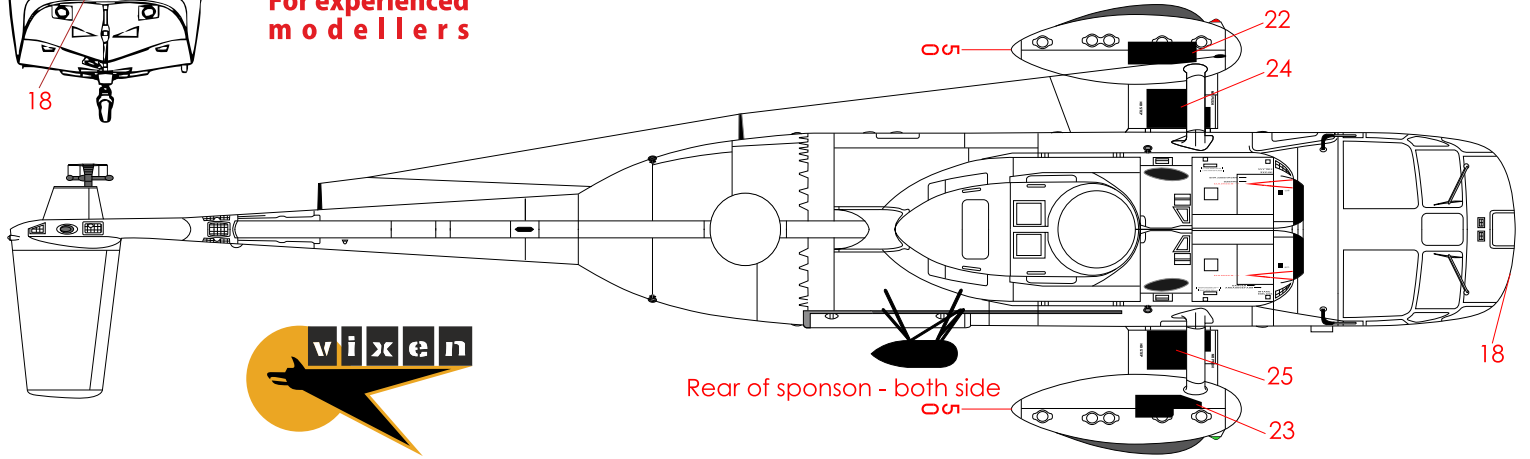

Rear of sponson - both side

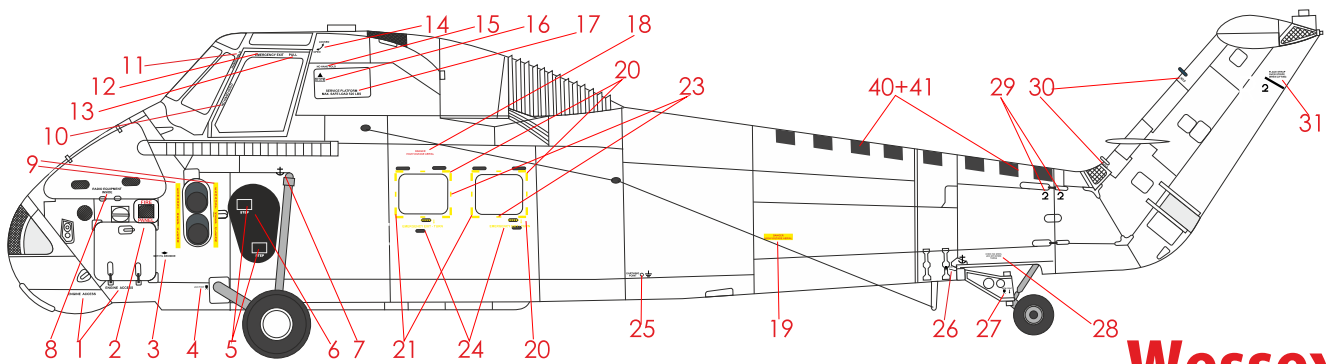

Wessex HAS.1

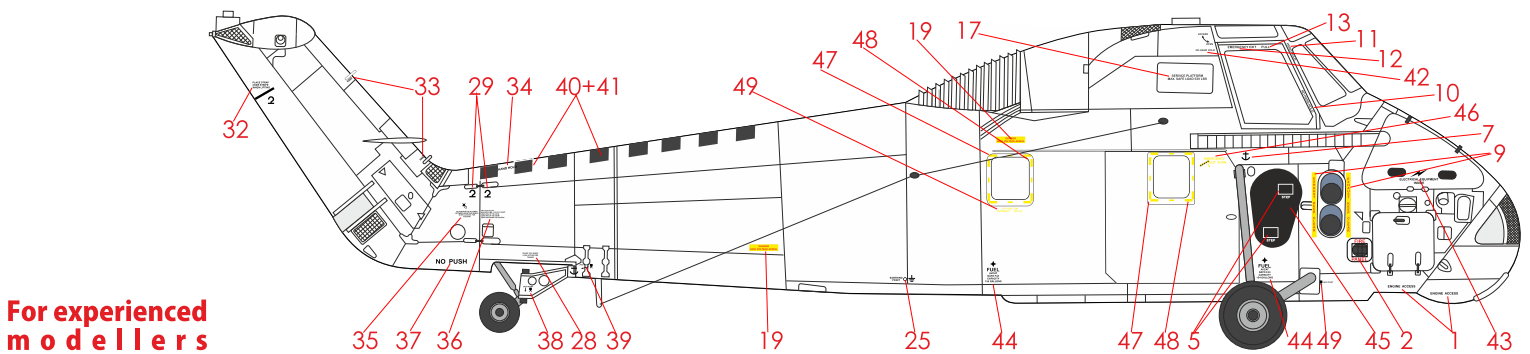

For experienced modellers

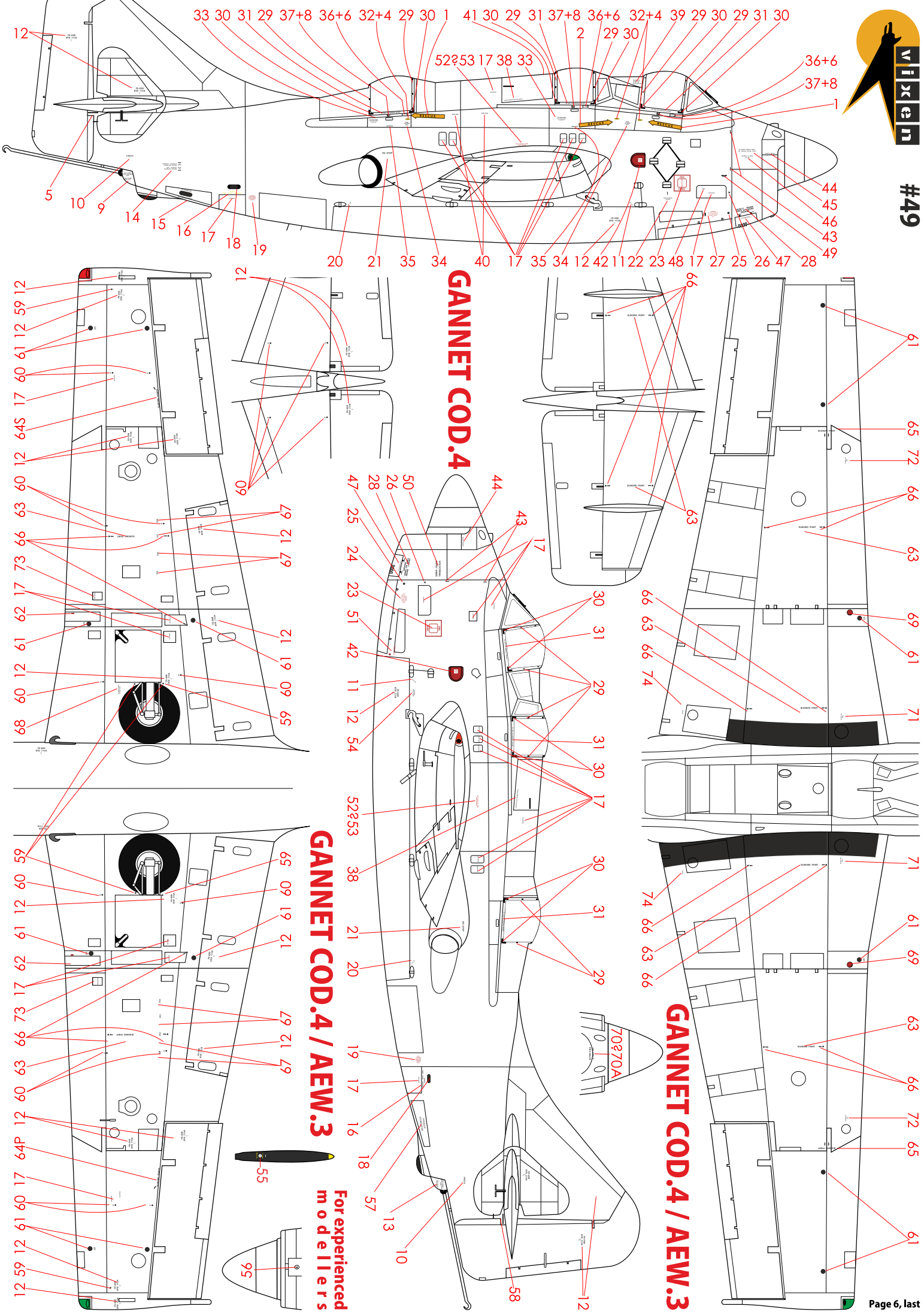

GANNET COD.4

GANNET COD.4 / AEW.3

GANNET COD.4 / AEW.3

For experienced
modelers

